

LDI-928

S E R I E S



150 amp peak quasi-cw laser diode array drivers.

Key Features

High Peak Current

Drives up to 50 Linear Arrays

Low Droop

Laser Diode Protection Circuits

Drives Low Impedance Loads

The LDI-928 provides high peak current for the SDL-3200 series linear or stacked quasi-cw laser diode arrays. Up to 150 A peak current is available at pulse widths from 50 to 1000 μ s. Diode protection circuits, current limit and transient control provide reliable diode drive. Variable compliance allows different versions of the LDI-928 to drive 1 to 50 quasi-cw linear arrays in electrical series.

Optimized for low impedance laser diode arrays, the LDI-928 provides transient free, high current pulses from a low inductance output port. Pulse rise time, overshoot, droop and decay time are optimized for the long quasi-cw pulse widths used by linear array or stacked array QCW laser diodes. Pulse width capability extends from 50 to 1000 μ s,

repetition rate is variable from 25 to 1000 Hz. The Replica feature allows one LDI-928 to control the pulse timing of other LDI-928 units connected to the master unit and allows the use of complex digital waveforms.

Adjustable current limit protects the laser diode from accidental overdrive. Individual controls for each electronic function and backlit meter provide ease of use, while current reset, turn-on delay and error indicators enhance operator efficiency. Error indicators are provided for current limit, overload, open and short circuit and remote interlock.

The LDI-928 meets the requirements of 21 CFR 1040.10 laser safety regulations.

	LDI-928-10	LDI-928-25	LDI-928-50
	Drives 1-10 Quasi-cw Linear Arrays in Electrical Series	Drives 1-25 Quasi-cw Linear Arrays in Electrical Series	Drives 10-50 Quasi-cw Linear Arrays in Electrical Series
Amplitude			
Range	10 to 150 A	10 to 150 A	10 to 150 A
Display Resolution	0.1 A	0.1 A	0.1 A
Accuracy	1 A + 2% of reading. When the laser is off, the displayed value is the amplitude setpoint (or current limit); when the laser is on, the displayed value is the actual current. The specification only applies to the actual current.	1 A + 2% of reading. When the laser is off, the displayed value is the amplitude setpoint (or current limit); when the laser is on, the displayed value is the actual current. The specification only applies to the actual current.	1 A + 2% of reading. When the laser is off, the displayed value is the amplitude setpoint (or current limit); when the laser is on, the displayed value is the actual current. The specification only applies to the actual current.
Current Limit			
Range	10 to 150 A	10 to 150 A	10 to 150 A
Display Resolution	0.1 A	0.1 A	0.1 A
Pulse Width			
Range	50 to 1000 µsec	50 to 1000 µsec	50 to 500 µsec
Display Resolution	1 µsec	1 µsec	1 µsec
Accuracy	4 µsec + 2 % of reading	4 µsec + 2 % of reading	4 µsec + 2 % of reading
Transition Time	10 µsec typical	10 µsec typical	10 µsec typical
Pulse Rate			
Range	25 to 1000 Hz	25 to 1000 Hz	25 to 1000 Hz
Display Resolution	1 Hz	1 Hz	1 Hz
Accuracy	2 Hz + 2 % of reading	2 Hz + 2 % of reading	2 Hz + 2 % of reading
Maximum duty cycle and average current	20% at 100 A, 13% at 150 A. The average current cannot exceed 20 A	10% at 100 A, 6.7% at 150 A. The average current cannot exceed 10 A.	5% at 100 A, 3.3% at 150 A. The average current cannot exceed 5 A.
Trigger In			
Type	Positive edge trigger	Positive edge trigger	Positive edge trigger
Signal Input	Accepts TTL or 5 V CMOS	Accepts TTL or 5 V CMOS	Accepts TTL or 5 V CMOS
Input Impedance	10 k ohms nominal.	10 k ohms nominal.	10 k ohms nominal.
Trigger Out			
Type	Digital form of the drive pulse. Positive slope for triggering.	Digital form of the drive pulse. Positive slope for triggering.	Digital form of the drive pulse. Positive slope for triggering.
Output Impedance	100 ohms nominal, one LSTTL or 5 V CMOS load.	100 ohms nominal, one LSTTL or 5 V CMOS load.	100 ohms nominal, one LSTTL or 5 V CMOS load.
Compliance			
Range	0 to 20 V	2 to 50 V	20 to 100 V
Display Resolution	0.1 V	0.1 V	0.1 V
Accuracy	0.1 V + 1% of reading.	0.1 V + 1% of reading.	0.1 V + 1% of reading.
Current Monitor			
Type	100 A/V, 1 V at 100 A. Typically within 1% of the displayed actual current.	100 A/V, 1 V at 100 A. Typically within 1% of the displayed actual current.	100 A/V, 1 V at 100 A. Typically within 1% of the displayed actual current.
Remote Interlock			
Open Circuit Voltage	5 VDC nominal, referenced to safety ground	5 VDC nominal, referenced to safety ground	5 VDC nominal, referenced to safety ground
Short Circuit Current	1 mA nominal	1 mA nominal	1 mA nominal
Type	Switch contact closure or TTL or 5 V CMOS compatible.	Switch contact closure or TTL or 5 V CMOS compatible.	Switch contact closure or TTL or 5 V CMOS compatible.
General			
Operating temperature	10 to 40 °C, noncondensing	10 to 40 °C, noncondensing	10 to 40 °C, noncondensing
Storage temperature	-40 to 75 °C	-40 to 75 °C	-40 to 75 °C
Power	90-130, 180-250 VAC, 48-66 Hz 750 W maximum @ 120 VAC 1000 VA maximum @ 120 VAC	90-130, 180-250 VAC, 48-66 Hz 750 W maximum @ 120 VAC 1000 VA maximum @ 120 VAC	90-130, 180-250 VAC, 48-66 Hz 750 W maximum @ 120 VAC 1000 VA maximum @ 120 VAC
Size (H x W x D)	6" x 17" x 17" (155 mm x 435 mm x 435 mm)	6" x 17" x 17" (155 mm x 435 mm x 435 mm)	6" x 17" x 17" (155 mm x 435 mm x 435 mm)
Weight	22 lbs.	22 lbs.	22 lbs.

LDI-928

S E R I E S

Driver Enclosure

Dimensions in inches (mm) except where indicated

Standard Tolerances

inches: x.xx = ±0.02
 x.xxx = ±0.010

mm: x.x = ±0.5
 x.xx = ±0.25

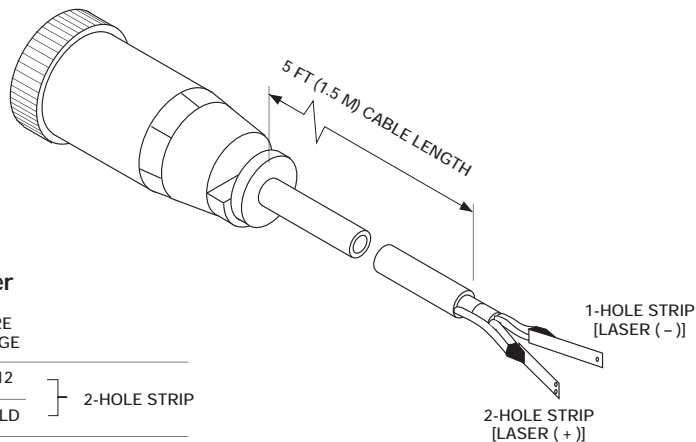
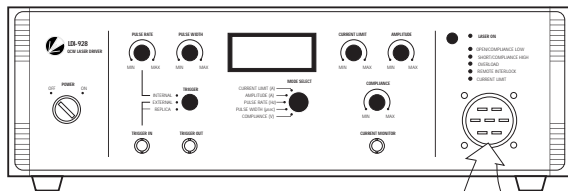
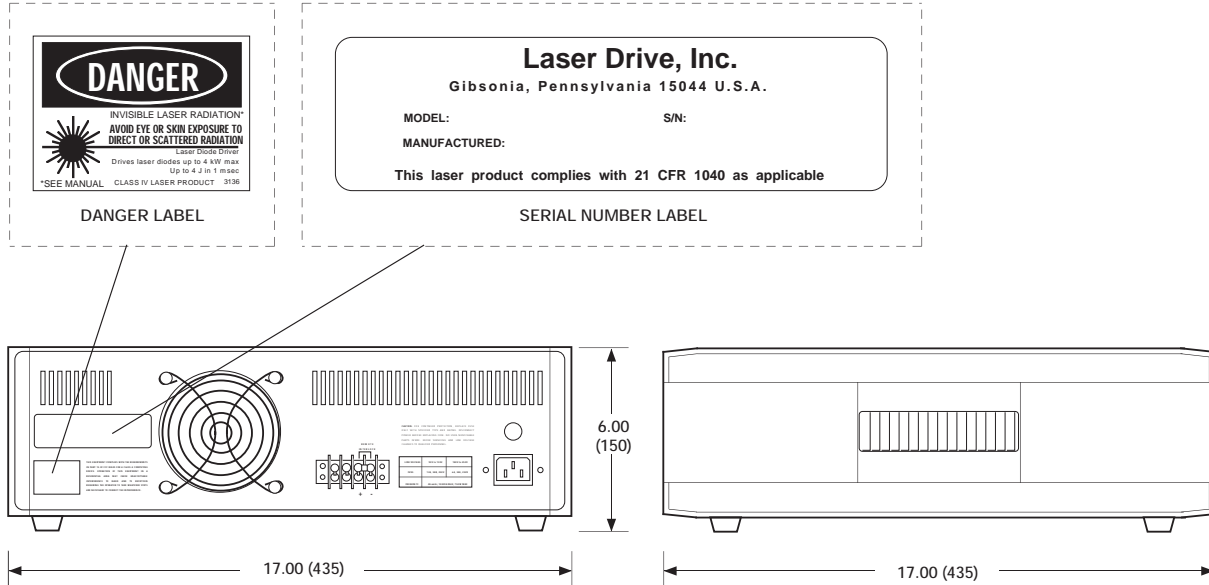

Output Cable Supplied with LDI-928 Driver

WIRE COLOR	WIRE FUNCTION	WIRE GAUGE	
BLK, RED	LASER (+) 1, 2	2 x 12	} 2-HOLE STRIP
OUTER	LASER (+) 3	SHIELD	
BRN, ORN	LASER (-) 1, 2	2 x 12	} 1 HOLE STRIP
INNER	LASER (-) 3	COAX	

Safety and Operating Considerations

The laser light emitted from this laser diode is invisible and may be harmful to the human eye. Avoid looking directly into the beam along its optical axis.

Operating the laser diode outside of its maximum ratings may cause device failure or a safety hazard. Power supplies used with the component must be employed such that the maximum peak optical power cannot be exceeded.

Quasi-cw laser diodes may be damaged by excessive drive current or switching transients. Use pulse current drivers specifically designed to eliminate transients in the output. Electrically short the array at all times when not in use.

Device degradation accelerates with increased temperature and therefore careful attention to minimize the case temperature is advised. For example, life expectancy will decrease by a factor of four if the case is operated at 50°C rather than 30°C.

A proper heat sink for the laser diode on a thermal radiator will greatly enhance laser life. Firmly mount the laser on a radiator having a thermal impedance of less than 0.5°C/W for increased reliability.

The LDI-928 Series drivers are designed to prevent transients. To prevent excessive drive current and possible safety hazard, the current limit control must be properly set for each individual laser diode.

CAUTION - USE OF CONTROLS OR ADJUSTMENTS OR PERFORMANCE OF PROCEDURES OTHER THAN THOSE SPECIFIED HEREIN MAY RESULT IN HAZARDOUS RADIATION EXPOSURE.



Laser Drive, Inc.
5318 Ranalli Drive
Gibsonia, Pennsylvania 15044
<http://www.laserdrive.com>
Tel: 724-443-7688 Fax: 724-444-6430